



**Hard wired
Carbon Monoxide Alarms**

Carbon Monoxide Alarm with battery backup



Why choose the SF340 Series:

- Unique 5 year module replacement system
- Up to 5 years battery back up
- Low maintenance & low cost of ownership
- Secure installation
- 230Vac & 12/24Vdc options
- Easy integration within existing systems
- Interconnect and relay output options
- Every alarm is tested and calibrated in carbon monoxide
- No re-wiring or main unit replacement costs

The SF340 Series is a range of reliable, hard wired carbon monoxide alarms with battery backup. They are designed for use in all domestic and light commercial environments.

Features & Benefits

Every unit in the SF340 series utilises the advanced ECO-Sure electrochemical cell sensing technology and comes complete with a full 10 year guarantee on the main unit and a full 5 year guarantee on each sensor module.

Every unit in the SF340 series offers up to 5 years battery backup allowing for continuous protection – even in the event of power loss. This also allows the unit to be operational whilst waiting for permanent installation.

Units can be provided to operate from various voltage options. 230Vac or 12/24Vdc units are all available for differing applications.

The SF340 has been specially designed for permanent, secure installation and is ideal for use by local authorities, housing associations and any organisation responsible for the safety of tenants and the maintenance of their homes.

The SF340 series of alarms incorporate a unique module replacement system. There are no re-wiring or main unit replacement costs, just a simple, clip-in module to change once every 5 years. This results in low ownership costs and minimal maintenance. Locking screws also ensure that only authorised persons can gain access to the unit.

Units are available with relay output and interconnect options. This enables connection to control panels, shut-off valves, remote alarms... etc, as well as allowing numbers of alarms to be linked together in series.

An internal diagnostic facility means the SF340 carries out continuous self-monitoring. If any fault is located in the sensor, battery or circuits, the unit will automatically give a warning signal within 60 seconds.

All gas appliances should be checked for safety annually.



**From Honeywell Analytics,
Europe's No.1 Manufacturer
and Supplier of Carbon
Monoxide Alarms.**

General specification



Specification

| | |
|-------------------------------------|--|
| Detection Principle: | Electrochemical cell |
| Operating Voltage: | 230Vac or 12/24Vdc |
| Backup Battery: | 9Vdc pp3 |
| Power Consumption: | <2.5W |
| Main Unit Life: | No replacement required (10 year guarantee) |
| Module Life: | 5 years (guaranteed) |
| Module Replacement Warning: | Double buzzer chirp every minute |
| Alarm Indication: | Buzzer and flashing red light |
| Buzzer Output: | 85 decibels (dB) at 3m |
| Operating Temperature Range: | -5 to +40°C |
| Alarm Levels: (BS7860: 1996) | 150ppm, between 10 to 30 minutes, 350ppm within 6 minutes |
| Weight: | 575g approx. |
| Dimensions: | 170 x 110 x 65mm |
| Test Facility: | Yes |
| Relay Output Fitted: | SF340F and SF340J |
| Models Available: | SF340E - 230Vac, SF340F - 230Vac + relay + interconnect SF340J - 12/24Vdc + relay + interconnect |

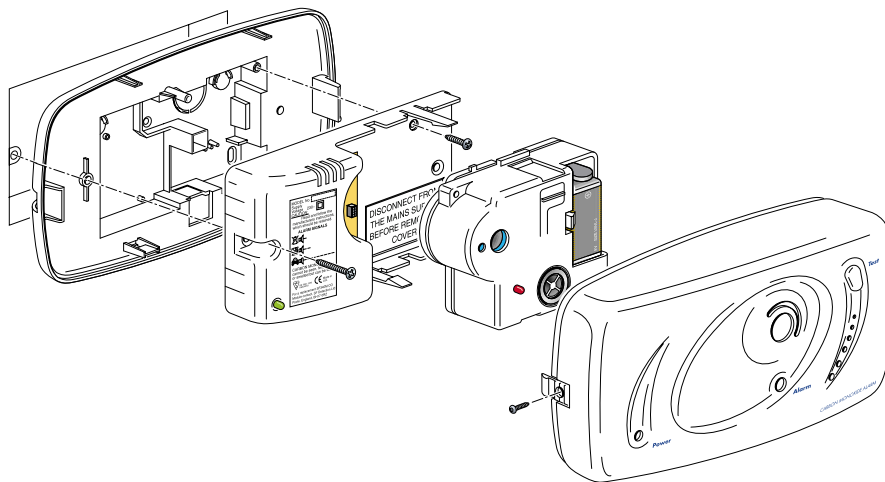

As world leaders in gas detection, the SF Detection range of domestic gas alarms is built around the same innovative and powerful sensing technology that powers Honeywell Analytics' professional range of gas detectors. The result is proven, reliable detection for a range of common gas hazards - providing complete peace-of-mind in the protection of people and property.

The SF Detection range of gas and smoke detection



SF350EN

Europe's best-selling domestic carbon monoxide alarm, the SF350EN uses the latest electrochemical sensor technology to give users an audible and visual warning long before the level of CO reaches a dangerous level.



SF340 Series

The SF340 carbon monoxide alarms are hard wired with long life battery back up. They also incorporate a low cost replacement sensor module ensuring low cost of ownership and low maintenance.



Z10 Series

The Z10 offers users a reliable early warning of a leak of either natural or LPG flammable gas in a range of domestic environments including homes and caravans. Both mains (110-230Vac) and DC battery (12-24Vdc) versions available.



Z10 LPG Boat

The Z10 LPG boat alarms with remote sensors are designed to give an early warning of LPG leaks on boats and come in single or dual sensor versions, which can operate from a 12-24V DC power supply.



e²sense

As a portable pen-shaped detector, e²sense is the most convenient way to detect flammable gas hazards from pipes, fittings, valves, gas storage tank/cylinders and hot water heaters. Will detect natural gas, LPG and LNG.

Find out more

www.honeywellanalytics.com

Contact Honeywell Analytics:

Europe, Middle East, Africa and Asia

Life Safety Distribution AG
4 Stinsford Road
Nuffield Industrial Estate
Poole, Dorset BH17 0RZ
Tel: +44 (0)1202 645577
Fax: +44 (0)1202 665331
gasdetection@honeywell.com

Americas

Honeywell Analytics Distribution, Inc.
400 Sawgrass Corporate Pkwy
Suite 100
Sunrise, FL 33325
USA
Tel: +1 954 514 2700
Toll free: +1 800 538 0363
Fax: +1 954 514 2784
detectgas@honeywell.com

Technical Services

ha.global.service@honeywell.com

www.honeywell.com

Please Note:

While every effort has been made to ensure accuracy in this publication, no responsibility can be accepted for errors or omissions. Data may change, as well as legislation, and you are strongly advised to obtain copies of the most recently issued regulations, standards, and guidelines. This publication is not intended to form the basis of a contract.

H_SF340_V2
03/07

© 2007 Honeywell Analytics

Honeywell